

The endocrine disruptor, 17 α -ethinyl estradiol, alters male mate choice in a freshwater fish

Minna Saaristo^{a,*}, Christopher P. Johnstone^a, Kun Xu^b, Mayumi Allinson^c, Bob B.M. Wong^a

^a School of Biological Sciences, Monash University, Victoria, Australia

^b Department of Renewable Resources, University of Alberta, Edmonton, Canada

^c Department of Chemical Engineering, The University of Melbourne, Victoria, Australia

ARTICLE INFO

Keywords:

Chemical communication
Emerging environmental contaminant
Endocrine-disrupting chemical
Ethinyl estradiol
Sexual selection

ABSTRACT

Among the handful of studies on the behavioural effects of endocrine disrupting chemicals (EDCs), only a few have set out to disentangle the mechanisms underpinning behavioural changes. In fish, previous studies have shown that both visual and chemical cues play an important role in mate choice. As such, contaminant-induced changes in either transmission or perception of mate choice cues could have direct implications for individual's fitness. One widespread contaminant of environmental concern is 17 α -ethinyl estradiol (EE2), a synthetic estrogen used in the contraceptive pill. Here, we investigated the impacts of EE2 exposure (28 days; measured concentration 14 ng/L) on visual and chemical communication in wild guppies (*Poecilia reticulata*). Using a standard dichotomous mate choice assay, we first gave individual males (either control or EE2-exposed) the opportunity to court two size-matched females (one control and one EE2-exposed) using only visual cues. We then introduced chemical cues of females (control and EE2-exposed) to the trial tank. We found that there was no significant effect of EE2-treatment on total time males spent associating with the females, when given only visual cues. There was, however, a significant effect on male courtship behaviour, with both control and EE2-exposed males spending more time performing 'sigmoid' displays towards the visual cues of control females compared to EE2-exposed females. When males were presented with both visual and chemical female cues simultaneously, we found that males spent more time courting control females that were paired with EE2-chemical cues. Not only does our study uncover a previously unknown behavioural impact of EE2-exposure on chemical cues, but demonstrates that EE2-exposure can exert complex effects on visual and chemical communication in a mate choice context. Finally, we contribute to the discussion of intraspecific variability by providing data on the potential trade-offs underpinning contaminant-induced behavioural changes.

1. Introduction

Aquatic habitats are increasingly being exposed to a wide range of chemical contaminants (e.g. herbicides, pharmaceuticals, pesticides, and personal care products) that can impact non-target organisms (Bergman et al., 2012; Arnold et al., 2014). This is particularly concerning because many of these emerging contaminants can target hormone receptors (e.g. endocrine disrupting chemicals, EDCs: Diamanti-Kandarakis et al., 2009) and/or directly alter behaviour (e.g. selective serotonin reuptake inhibitors: Arnold et al., 2014) even at very low levels. The increasing production and release of chemicals mean that non-target organisms, in both terrestrial and aquatic environments, are continuously exposed to chemical contaminants. Our current knowledge regarding the impacts of exposure on non-target organism is still rather limited and tools to detect early-warning signs of contamination

are crucially needed. Behaviour, which, for many animals, presents the first response to changes in the environment (Wong and Candolin, 2015), provides a comprehensive and sensitive measure for investigating how wildlife can be impacted by chemical pollution (Clotfelter et al., 2004; Zala and Penn, 2004; Melvin and Wilson, 2013; Saaristo et al., 2018).

Evidence suggests that reproductive behaviours may be especially susceptible to chemical contaminants. In many species, males and females can be highly selective about their choice of mates, as animals often assess the quality of potential suitors based on a range of traits, including colourful ornaments and conspicuous sexual displays (Darwin, 1859; Andersson, 1994). Importantly, the expression of these sexually selected traits are often finely attuned to the local environmental conditions in which they have evolved. So, what happens when these conditions are modified as a result of chemical pollution?

* Corresponding author.

E-mail address: minna.saaristo@monash.edu (M. Saaristo).

<https://doi.org/10.1016/j.aquatox.2019.01.006>

Received 31 October 2018; Received in revised form 19 December 2018; Accepted 8 January 2019

Available online 09 January 2019

0166-445X/ © 2019 Elsevier B.V. All rights reserved.

Contaminant-induced alteration in either the transmission or perception of cues are likely to have a direct bearing on reproductive success and, hence, fitness (Tierney et al., 2010). Indeed, previous studies have shown that exposure to emerging chemical contaminants can affect mate choice communication and behaviour in a range of taxa, including fish (Saaristo et al., 2009a, 2010a; Bertram et al., 2015; Frankel et al., 2016; Tomkins et al., 2018), amphibians (Park et al., 2001; Hoffmann and Kloas, 2012), birds (Bean et al., 2014; Pandey et al., 2017) and mammals (Crews et al., 2007). These studies also highlight the fact that chemical contaminants can affect mate choice cues across a range of different sensory modalities (visual, acoustic, olfactory). Yet, despite this, as far as we are aware, no studies have considered the impact of emerging contaminants on different channels of sexual communication simultaneously. This is true even though multiple cues across multiple modalities are often employed in mate choice (Candolin, 2003).

One chemical contaminant of concern is 17 α -ethinyl estradiol (EE2), a synthetic estrogen used in the oral contraceptive pill. In 2015, over 80 million married or in-union women around the world were estimated to use the contraceptive pill (United Nations, 2015). Unsurprisingly, perhaps, EE2 has now been reported in surface and effluent waters worldwide at concentrations ranging from 0.1 ng/L (Hannah et al., 2009; King et al., 2016) to 11 ng/L (Lima et al., 2013; Tiedeken et al., 2017). While discharge of pharmaceutical-tainted effluent from wastewater treatment is a primary contributor of EE2 in the environment, agricultural run-off (e.g. estrogens excreted by livestock) is another important source of contamination (Adeel et al., 2017). As EE2 targets an evolutionarily conserved biological pathway (Ankley et al., 2007), it has been shown to affect a wide range of non-target organisms. For example, EE2 has been implicated in causing reproductive malformations and defects (e.g. Holm et al. 2006; Santos et al., 2014; Vu et al., 2015), altered mating behaviours (Bell, 2001; Saaristo et al., 2009b, 2010b; Hoffman and Kloas 2012; Derouiche et al., 2015) and even population decline in exposed wildlife (Kidd et al., 2007).

Guppies (*Poecilia reticulata*) are an ideal species for exploring the impacts of chemical contaminants, such as EE2, on visual and chemical communication. The guppy is a small, sexually dimorphic freshwater fish native to north-eastern South America but has been introduced into tropical regions around the world, including Australia (Corfield et al., 2008). Guppies are a model species in behavioural ecology, and their reproductive behaviours are well characterized (Houde, 1997). Guppies are a live-bearing species, with males using their gonopodium (a modified anal fin) as an intromittent organ to inseminate females. Males, in this regard, can employ two alternate mating strategies to achieve mating success: they can either court females using 'sigmoid' displays (Houde, 1997), or engage in sneak or forced (unsolicited) copulations (Luyten and Liley, 1991). Most studies of mate choice in guppies have tended to focus on female choice, with evidence that females can be highly selective in their choice of mating partners (Ender, 1980; Magurran and Seghers, 1994; Brooks and Ender, 2001). However, male guppies can also be choosy (Houde, 1997; Dosen and Montgomerie, 2004; Herdman et al., 2004) and are known to attend to both visual and chemical cues in mate assessment (Herdman et al., 2004; Guevara-Fiore et al., 2009; Crow and Liley, 2011).

Accordingly, the aim of this study was to investigate the impacts of a short-term (28-day) exposure to 17 α -ethinyl estradiol (14 ng/EE2/L) on visual and chemical communication in the guppy. Based on previous studies, we predicted that EE2-exposed males should spend less time associating with, and courting, females (Saaristo et al., 2009b, 2010a, b). However, it remains unclear how visual cues of EE2-exposed and unexposed females might interact with chemical cues to influence the strength and direction of male mating preferences.

2. Materials and methods

2.1. Collection and housing

As with our previous behavioural ecotoxicology research (e.g. Tomkins et al., 2016; Saaristo et al., 2017; Bertram et al., 2018), wild adult guppies were collected from Alligator Creek (19°26'17.94"S, 146°57'1.09"E) in Queensland, Australia. The guppies were caught using dip nets from shallow pools adjacent to the Bowling Green Bay National Park. Water quality testing confirmed that this guppy population had not been previously exposed to pharmaceuticals (ALS group, Environmental Division, unpubl. data). Fish were brought back to Monash University (Melbourne) and acclimated to laboratory conditions ($+ 26\text{ }^{\circ}\text{C} \pm 1$, 12:12 h light:dark regime) for two months in 54 L tanks (20 fish per tank) prior to exposure. Fish were fed *ad libitum* once daily with commercial fish pellets (Otohime Hirame larval diet, 580–910 mm).

2.2. Exposure design

After acclimation, fish were exposed to EE2 for 28 days via a flow-through system using previously published methods (Saaristo et al. 2013; Martin et al., 2017; Tomkins et al., 2017). Briefly, this system included 16 exposure tanks (60 × 30 × 24 cm; 28 fish per tank), which was made up of 8 EE2-exposed tanks (containing 17 α -ethinyl estradiol), and 8 control tanks (containing a solvent control = 0.00004% ethanol). Guppies in the EE2-exposed tanks were exposed to EE2 at a nominal concentration of 20 ng/L (measured mean concentration = 14 ng/L, SE = 1.70 ng/L, n = 32). During the exposure period, water samples were taken weekly from the exposure tanks and measurement of EE2 concentration was conducted using a commercial kit (Ecologiena, EE2 ELISA Kit, Tokiwa Chemical Industries, Japan) in accordance with the manufacturer's instructions, with minor modifications (Saaristo et al. 2013). A total of 448 fish (224 males, 224 females) were randomly taken from the holding tanks and placed into the exposure tanks, with the sexes kept separately. Exposure aquaria contained 2 cm of natural gravel substrate, a large stone for refuge, an airstone, and an aquarium heater. Exposure tanks were kept on a 12:12 h light:dark cycle and were monitored daily for flow-through rates (24 h cycling, ~ 1.67 L/h per tank) and temperature (~ 25–27 °C). Fish subsisted on the same diet regime as that used during the acclimation period.

2.3. Behavioural assays

After 28 days, fish were randomly selected for behavioural assays. To examine the impact of EE2 on male mate choice, we ran dichotomous choice assays testing the association preferences and courtship behaviour of individual males (i.e. control and EE2-exposed; N = 33 for each treatment) when presented with visual and chemical cues from EE2 exposed and unexposed females. Males were tested in aged, carbon-filtered tap water in experimental tanks (60 cm x 30 cm x 24 cm) containing a 2 cm layer of gravel. Each trial consisted of two distinct stages based on the methods of Guevara-Fiore et al. (2009) (see below). During stage 1, male behaviours were assessed when presented with female visual cues while, in stage 2, males were tested in the presence of female visual and chemical cues simultaneously. To disentangle the relative importance of these cues in male mate choice during stage 2, we either matched or mismatched the visual and chemical cues of exposed and unexposed females being presented to the males.

2.3.1. Stage 1: female visual cues

A sized matched control and EE2-exposed female (Mann-Whitney *U* test of standard lengths, $W = 2574.5$, $p = 0.946$), each housed in individual tanks (10 cm x 30 cm x 24 cm), were placed at opposite ends of the main experimental aquarium (Fig. 1), and given 5 min to acclimate. Following this, we introduced a single male (i.e. either control or EE2

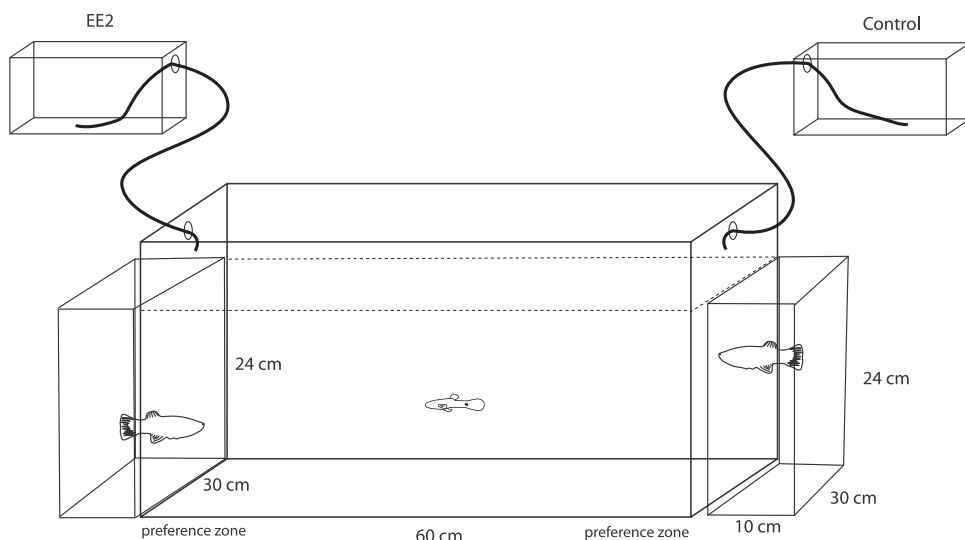

Fig. 1. Experimental set-up used in the behavioural trial. The experimental tank was divided into two preference zones (red) and one middle neutral zone (black). A sized matched control and EE2-exposed female, each housed in individual tanks were placed at opposite ends of the main experimental aquarium. The olfactory cues were placed above the trial tank in individual glass tanks (chemical cue), each with a silicon tube connected to a peristaltic pump (Watson Marlow) to maintain the flow rate at the wanted level (2 mL/min).

exposed) into the middle of the main experimental tank, where he was allowed to acclimate for 5 min inside a container. After the acclimation period, the male was gently released. The behaviour of the male was then filmed for 5 min using a Canon PowerShot S120 camera. In particular, from these recordings, we quantified the time males spent associating with each female. The male was deemed to be associating with a female if he was within 5 cm of her aquarium (i.e. female 'preference' zone). Association time, in this regard, is a reliable indicator of male mate choice in Poeciliid fish (Wong et al., 2007; Walling et al., 2010; Jeswiet and Godin, 2011), and is commonly used as a measure of male mating preference in guppies (e.g., Houde, 1997; Herdman et al., 2004; Dosen and Montgomerie, 2004; Gasparini et al., 2013). In addition to association time, we also quantified the number and duration of male courtship 'sigmoid' displays directed towards each of the females over the 5 min sampling period.

2.3.2. Stage 2: female visual and chemical cues

The experimental procedure (i.e. experimental tank set up and behaviours quantified) during stage 2 was identical to that described in stage 1, with the exception that, in addition to the visual cues of exposed and unexposed females, we also added female chemical cues to the main experimental tank housing the male and filmed the male for 10 min. The chemical cues were channelled from the collecting tanks at a rate of 2 mL/min using peristaltic pumps (Watson Marlow) into the main experimental tank directly above each of the female preference zone, with chemical cues of exposed and unexposed females either matched or mismatched to the exposure status of the female in the adjacent tanks.

Female chemical cues used in stage 2 were prepared and collected prior to the start of the trials. To do this, 24 h before the commencement of trials, five sexually mature females were randomly selected, and placed into 5 L glass 'collection' tanks that contained aged, carbon filtered tap water. Each 5 L tank was located adjacent to another aquarium containing 2–3 males to provide females with visual stimulation. After the 24 h period, females were removed from collection tanks, and stimulus water was then used during the stage 2 of experiments within 12 h (Wong et al., 2005; Guevara-Fiore et al., 2009). On any given day, we obtained chemical cues separately from control and EE2 exposed females (using two separate batches of females for each treatment).

The behaviours of males (see above) were quantified blind to treatment from the video recordings obtained during stages 1 and 2 using the event-recording software JWatcher V1.0.

2.4. Statistical analysis

All analyses were conducted using linear mixed effects models where the male fish was a random effect in the model ('lme' in 'nlme'). Male fish was included as a random effect because the data collation resulted in two lines of data per male fish, and if male fish were not included as a random effect then the results would be pseudoreplicated. Exposure tank and trial tank were investigated early on as possible random effects, but neither explained substantive variance in the response variables (always < 1%), so these were excluded from subsequent models. Because we were using a classical hypothesis testing approach, REML was used to fit models. To obtain degrees of freedom, F, and p-values, the 'anova' function (in 'stats') was applied to the 'lme' model. Used in this way, 'anova' returns an ANOVA-like results table for any suitable fitted model. This was used in preference to 'summary' because the key predictors of interest were categorical, and an ANOVA table was deemed to be more appropriate than the multiple regression-like table generated using 'summary'. The response was always behavioural of interest (e.g. total time in female preference zone), and the fixed effects (predictors) were male treatment (EE2 or control), female treatment (EE2 or control) and chemical cue (EE2 or control). Female and male standard lengths were also included as covariates to control for fish size. Female fish mass was not included in the models because it strongly and significantly correlated with standard length (Pearson's correlation test, $r = 0.919$, $p < 0.001$). As per standard Type I sums of squares models, we placed covariates early in the model and predictors of interest later in the model. The structure of the main effects was always the same, specifically: 'behavioural response' as a function of 'male standard length' + 'female standard length' + 'male treatment' + 'female treatment' + 'chemical cue'. Assumptions were tested by examining diagnostic plots, and response data always required transformation to meet assumptions. A rank normalisation transformation was used ('rntransform' in GenABEL) for the transformation in all cases. This transformation ranks all data in an observed set and then positions the ranked data on a normal curve to generate final transformed values. The principle is similar to the ranking in a Spearman's rank correlation, or a Kendall's tau non-parametric correlation (Quinn and Keyough, 2002). In effect, this approach converted the LME models to non-parametric tests. Non-parametric tests run a slightly inflated Type II error, and although not ideal we consider this acceptable. This method was preferred to exploring generalised linear mixed effects models (GLMM). GLMM are substantially more mathematically complicated than LME, and our preference is to use the least mathematically complicated of the valid options available.

When examining results, we first checked all possible interaction

terms for the predictors of interest in models (i.e. interactions of the factorial predictors, 'male treatment', 'female treatment' and 'chemical cue'). Although we checked for three and four-way interactions, the only interactions that were $p < 0.1$ involved just two predictors (where investigating interaction terms, a more conservative way to investigate interactions is to examine any $p < 0.1$) (Quinn and Keyough, 2002). Interaction terms that were $p > 0.1$ were discarded from the final models. Investigation of interactions that were $p < 0.1$ requires disentangling the main effects (Engqvist, 2005), and was undertaken here by straightforward splitting and subgroup analysis (i.e. splitting by one of the factors of interest to disentangle the interactive effects on the other variable of interest) (Quinn and Keyough, 2002). Note that because the time of the visual cue experiment (stage 1) was 5 min and the time of the visual and chemical cue experiment was 10 min (stage 2) a between-stages analysis was not viable. As such the models were constructed only to examine within-stage differences associated with the fish treatments (EE2 or control) or covariates (e.g. male standard length, female standard length). Finally, although the chemical cue had not been introduced in stage 1, we checked for chemical cue effects regardless (i.e. in case there was an unidentified confounding factor that was associating with the chemical cues). However, as expected, chemical cues had no significant effect on any behaviour in stage 1 (p always > 0.770).

We also investigated whether exposure tank (i.e. tanks used to house fish over the 28 day period) or trial tank (i.e. tanks used for the specific behavioural experimental trials) showed any association with male behaviours, but found low non-significant associations (R^2 was always < 0.026). As such, to avoid over-complicating the models, we opted not to include the exposure or trial tank as a possible effect. Finally, note also that the results for the covariates (male and female standard lengths) are not reported, as they were simply included to control for known effects (Houde, 1997) and did not pertain to the hypotheses.

3. Results

3.1. Stage 1: female visual cues

When males were presented only with visual cues of females, there were no significant interaction terms ($p < 0.1$) in the total time males spent associating with females. Further, we found no significant main effects of male (lme: $F_{1,54} = 0.02$, $p = 0.890$) or female EE2-treatment ($F_{1,39} = 0.69$, $p = 0.413$) on total time males spent associating with the females (Fig. 2a). Similarly, male exposure status did not affect sigmoid display duration or frequency ($F_{1,53}$, $P > 0.128$). However, there was a significant effect on total time performing ($F_{1,53} = 4.51$, $p = 0.038$) and frequency ($F_{1,53} = 5.10$, $p = 0.028$) of sigmoid displays, with both control and EE2-exposed males spending more time performing sigmoid displays, and more frequently, towards control females compared to EE2-exposed females (Figs. 3a and 4 a).

3.2. Stage 2: Female visual and chemical cues

When males were presented with both visual and chemical female cues contemporaneously, the total time spent in the association zone was not dependent on male ($F_{1,59} = 0.81$, $p = 0.373$) or female treatment ($F_{1,58} = 0.06$, $p = 0.811$), or chemical cue ($F_{1,58} = 2.31$, $p = 0.134$) (Fig. 2b). In stark contrast to these findings, there was a significant interaction of female treatment and chemical cue treatment on male sigmoid display durations ($F_{1,53} = 4.51$, $p = 0.038$), and frequencies ($F_{1,53} = 5.10$, $p = 0.028$). As the slopes of this interaction term are reversed (Figs. 3b, 4 b), the implication is that males preferred females when paired with mismatched cues (i.e. the most preferred were control females paired with an EE2-exposed female cue, and EE2-exposed females paired with a control female cue). When we examined sub-group analyses of meaningful biological comparisons, the pairwise

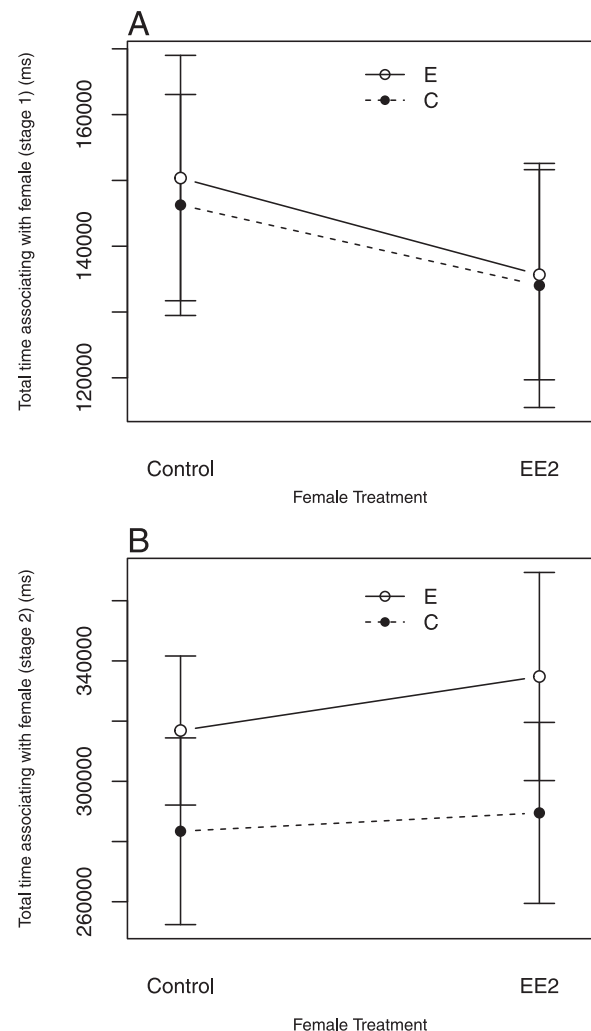

Fig. 2. The mean (± 1 SE) total time (ms) males spent associating with females when presented with (A) female visual cues only (stage 1), and (B) visual and chemical cues simultaneously (stage 2). Figure shows pooled data for control and exposed males as there was no effect of male exposure status on the time spent associating with females. On the x-axis, 'control' refers to the visual cues of control females and 'EE2' refers to the visual cues of EE2-exposed females. The open points and solid lines in the figure refer to the trials in which males were subsequently (i.e. during stage 2) presented with the chemical cues of control females (C), and the closed points and dashed lines refer to trials in which males were subsequently presented with the chemical cues of EE2-exposed females (E).

results broadly support this interpretation. Specifically, control females paired with EE2-chemical cue were preferred to control females paired with control chemical cue (sigmoid duration: $F_{1,52} = 4.28$, $p = 0.044$; sigmoid events: $F_{1,52} = 4.53$, $p = 0.038$), and were also preferred to EE2-exposed females paired with an EE2-chemical cue (sigmoid duration: $F_{1,52} = 4.80$, $p = 0.033$; sigmoid events: $F_{1,52} = 4.23$, $p = 0.045$). There was also a consistent but marginal trend towards preferring EE2-exposed females with a control chemical cue over control females paired with a control chemical cue (sigmoid duration: $F_{1,52} = 3.37$, $p = 0.072$; sigmoid events $F_{1,52} = 2.84$, $p = 0.098$), and over EE2-exposed females paired with an EE2-chemical cue (sigmoid duration: $F_{1,52} = 3.31$, $p = 0.075$; sigmoid events: $F_{1,52} = 3.54$, $p = 0.066$). The overall implication is that the most preferred female and chemical cue pairing were control females paired with EE2-chemical cues.

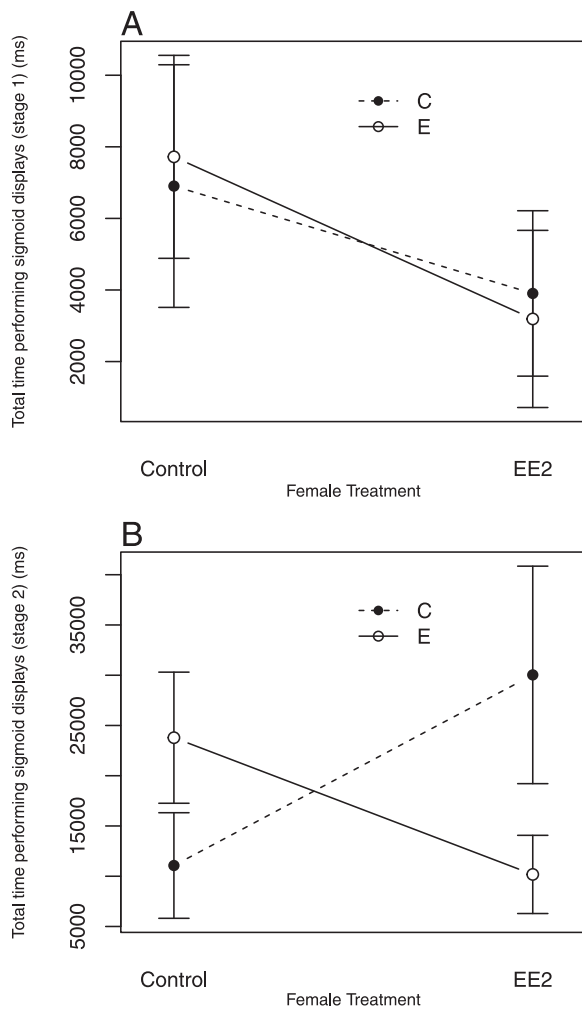

Fig. 3. The mean (± 1 SE) total time (ms) male performed sigmoid displays towards females when presented with (A) female visual cues only (stage 1), and (B) visual and chemical cues simultaneously (stage 2). Figure shows pooled data for control and exposed males. On the x-axis, ‘control’ refers to the visual cues of control females and ‘EE2’ refers to the visual cues of EE2-exposed females. The open points and solid lines in the figure refer to the trials in which males were subsequently (i.e. during stage 2) presented with the chemical cues of control females (C), and the closed points and dashed lines refer to trials in which males were subsequently presented with the chemical cues of EE2-exposed females (E).

4. Discussion

Here, we report that exposure to field-detected levels of EE2 impacts the mate choice responses of males to female visual and chemical cues. Importantly, we found that these responses are dependent on the interaction between female exposure status and whether the chemical cue was matched to the visual cue of the female. Specifically, when males were given only female visual cues, both control and EE2-exposed males directed more sigmoid displays to control females. Further, when males were given both visual and chemical female cues, males, irrespective of their own exposure status, spent more time performing sigmoid displays, and performed displays more frequently, when control females were paired with EE2-chemical cue than with control-chemical cue. Not only does our study uncover a previously unknown behavioural impact of EE2-exposure on chemical cues, but also raises the possibility that EE2-exposure may have complex effects on different sensory modalities and mate choice cues.

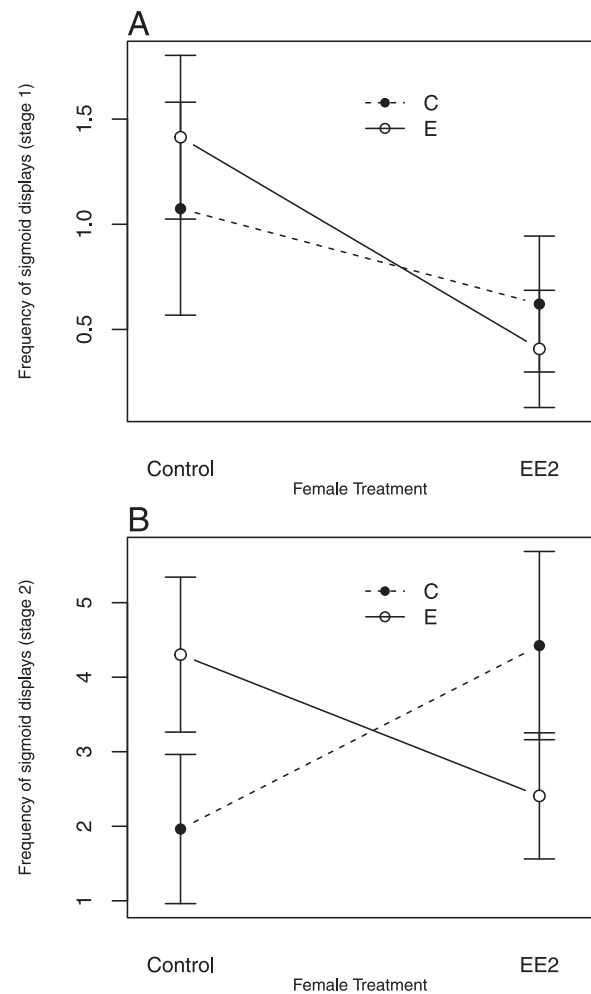

Fig. 4. The mean frequency of male performing sigmoid displays towards females when presented with (A) female visual cues only (stage 1), and (B) visual and chemical cues simultaneously (stage 2). Figure shows pooled data for control and exposed males. On the x-axis, ‘control’ refers to the visual cues of control females and ‘EE2’ refers to the visual cues of EE2-exposed females. The open points and solid lines in the figure refer to the trials in which males were subsequently (i.e. during stage 2) presented with the chemical cues of control females (C), and the closed points and dashed lines refer to trials in which males were subsequently presented with the chemical cues of EE2-exposed females (E).

4.1. Visual communication

When presented only with female visual cues (stage 1), we found that both control and EE2-exposed males spent significantly more time performing sigmoid displays, and more frequently, towards control females compared to EE2-exposed females. This indicates that EE2-exposure had no effect on male reproductive behaviour. Compared with previous research, our findings are consistent with some studies (zebrafish, *Danio rerio*: Larsen et al., 2008; Colman et al., 2009; Coe et al., 2010; Henriksen et al., 2016; medaka, *Oryzias latipes*: Lee et al., 2014), but not others (fathead minnow, *Pimephales promelas*: Majewski et al., 2002; Salierno and Kane, 2009; sand goby, *Pomatoschistus minutus*: Saaristo et al., 2009a, 2010a,b). Why? First, contrasting results among species could be due to differences in mating systems and reproductive investment (Ros et al., 2004; Magee et al., 2006). For example, fathead minnows and sand gobies both exhibit parental care. It has been suggested that exogenous estrogen down-regulates endogenous androgen production in males (Borg, 1994; Bell, 2001), leading to reduction in behaviours that are related to circulating

androgen levels. In this regard, previous studies have shown that, in such species, androgen levels are high during courtship (Knapp et al., 1999; Pankhurst et al., 1999; Rodgers et al., 2006) but are down-regulated when looking after offspring (Wingfield et al., 1990; Oliveira et al., 2002; Hirschenhauser and Oliveira, 2006). Second, even though a reduction in courtship behaviour was not observed in the current study, this does not negate the possibility that such behaviours may be impacted at higher exposure concentrations. For instance, in medaka (*Oryzias melastigma*), EE2-exposure had no influence on reproductive behaviours at 10 ng/L, but significant decreased courtship displays and mating attempts at 50 ng/L or above (up to 100 ng/L) (Lee et al., 2014). Third, another reason for discrepancies among studies could be the wide range of behavioural assays used to test impacts of chemical contaminants on mate choice. In this regard, use of standardised assays across species could help to redress this potential issue. As the focus of this study is on male behaviour, it is not possible to state whether EE2-exposure had any effects on female visual signalling (i.e. whether EE2-exposure altered visual signals performed by females), and this would form an interesting avenue for future research.

4.2. Chemical communication

We found that EE2-exposure affected female chemical cues. Increasing evidence shows that anthropogenic chemicals, such as EDCs, can interfere with the function and structure of olfactory sensory neurons and, thus, alter chemical communication (Lurling and Scheffer, 2007; Tierney et al., 2010). For example, in insects, exposure to insecticides have been found to increase female pheromone production and, in so doing, heighten the attractiveness of exposed females to males (Delpuech et al., 1998, 1999; Lurling and Scheffer, 2007). Similarly, if EE2 exposure enhances pheromone production in guppies, as our study suggests, this could potentially explain why males performed more sigmoid displays and more frequently, when the control female was matched with chemical cues from EE2 females. Indeed, there is now increasing evidence showing that chemical contaminants can be hugely disruptive to pheromone signalling. Moreover, these pernicious chemicals not only affect female pheromone production, but can also impact the ability of males to detect and respond to female pheromones, as has been shown in salmon (*Salmo salar*) exposed to a synthetic pyrethroid pesticide (Moore and Waring, 1996, 1998, 2001). Importantly, changes to male responses towards female chemical cues can have a direct bearing on male fitness, as was shown in male newts (*Notophthalmus viridescens*), where exposure to the insecticide endosulfan delayed the response of males towards female odours and, consequently, led to a reduction in male mating success (Park et al., 2001; Park and Propper, 2002).

4.3. Dissolution of sexual signals

Our study showed that visual and chemical cues had an interactive effect on male behavioural responses. Specifically, males, irrespective of their own exposure status, preferred control females paired with EE2-chemical cues. In fish, previous studies have shown that females base their mate choice on multiple cues (Candolin, 2003; Wong and Candolin, 2005; Lehtonen et al., 2007) and that both visual (e.g. courtship) and chemical (e.g. pheromone) channels of communication can play an important role in mate choice (Guevara-Fiore et al., 2009; Lehtonen and Kvarnemo, 2015). There is now mounting evidence that anthropogenic changes could affect different sensory modalities, with implications for the efficacy of different cues and signals important in mate choice (Tierney et al., 2010; Wong and Candolin, 2015). In threespined sticklebacks (*Gasterosteus aculeatus*), for example, eutrophication compromises the utility of visual signals by reducing visibility in the water column (Wong et al., 2007) but bolsters chemical communication through elevated pH (Heuschele and Candolin, 2007). By contrast, exposure of swordtail fish (*Xiphophorus birchmanni*) to

humic acid compromised the efficacy of chemical cues, while leaving visual mating preferences unaffected (Fisher et al., 2006). Such studies underscore the complex ways in which human altered conditions to the signalling environment, including the effects of chemical pollution, can impact both visual and chemical communication of fish.

5. Conclusions

Our study shows that exposure to EE2 alters male mate choice. Specifically, we found that males directed more sigmoid displays to control females compared to EE2-exposed females, when given only visual cues. Interestingly, when males were presented with both visual and chemical female cues simultaneously, males actually spent more time courting control females paired with EE2 chemical cues. Not only does our study uncover a previously unknown behavioural impact of EE2-exposure on female chemical cues, but also raises the possibility that EE2-exposure may have complex effects on mate attractiveness. Importantly, it highlights that changes to male responses towards female chemical cues can have a direct bearing on male fitness. Our results, among the first to disentangle multiple mate choice cues in the context of chemical pollution, underscores the importance of studying multiple sensory modalities simultaneously. Finally, we contribute to the discussion of intraspecific variability by providing data on the potential trade-offs underpinning contaminant-induced behavioural changes.

Ethical statement

The methods for animal housing, handling and experimental protocols were assessed and approved by the Biological Sciences Animal Ethics Committee at Monash University (permit number: BSCI/2013/09) and complies with all relevant State and Federal laws of Australia.

Funding statement

This study was supported by an Academy of Finland Postdoctoral Researcher Fellowship (265629) (to MS), and a Discovery Grant from the Australian Research Council (DP160100372) (to BMW).

Acknowledgements

We thank Anniina Saarinen for assistance with the flow-through exposure and behavioural assays.

References

- Adeel, M., Song, Z., Wang, Y., Francis, D., Yang, Y., 2017. Environmental impact of estrogens on human, animal and plant life: a critical review. *Environ. Intern.* 99, 107–119.
- Andersson, M.B., 1994. *Sexual Selection*. Princeton University Press, Princeton.
- Ankley, G.T., Brooks, B.W., Huggett, D.B., Sumpter, J.P., 2007. Repeating history: pharmaceuticals in the environment. *Environ. Sci. Technol.* 41, 8211–8217.
- Arnold, K.E., Brown, A.R., Ankley, G.T., Sumpter, J.P., 2014. Medicating the environment: assessing risks of pharmaceuticals to wildlife and ecosystems. *Philos. Trans. Biol. Sci.* 369, 20130569.
- Bean, T.G., Boxall, A.B.A., Lane, J., Herborn, K.A., Pietravalle, S., Arnold, K.E., 2014. Behavioural and physiological responses of birds to environmentally relevant concentrations of an antidepressant. *Philos. Trans. Biol. Sci.* 369, 20130575.
- Bell, A.M., 2001. Effects of an endocrine disruptor on courtship and aggressive behavior of male three-spined stickleback, *Gasterosteus aculeatus*. *Anim. Behav.* 62, 780.
- Bergman, A., Heindel, J.J., Jobling, S., Kidd, K.A., Zoeller, R.T., 2012. WHO (World Health Organization)/UNEP (United Nations Environment Programme) Global Assessment of the State-of-the-science of Endocrine Disruptors. http://www.who.int/ipcs/publications/new_issues/endocrine_disruptors/en.
- Bertram, M.G., Saaristo, M., Baumgartner, J.B., Johnstone, C.P., Allinson, M., Allinson, G., Wong, B.B.M., 2015. Sex in troubled waters: Widespread agricultural contaminant disrupts reproductive behaviour in fish. *Horm. Behav.* 70, 85–91.
- Bertram, M.G., Ecker, T., Wong, B.B.M., O'Bryan, M., Baumgartner, J., Martin, J.M., Saaristo, M., 2018. The antidepressant fluoxetine alters mechanisms of pre- and post-copulatory sexual selection in the eastern mosquitofish (*Gambusia holbrooki*). *Environ. Pollut.* 238, 238–247.

- Borg, B., 1994. Androgens in teleost fishes. *Comp. Biochem. Physiol. C, Pharmacol. Toxicol. Endocrinol.* 109, 219–245.
- Brooks, R., Endler, J.A., 2001. Direct and indirect sexual selection and quantitative genetics of male traits in guppies (*Poecilia reticulata*). *Evol.* 55, 1002–1015.
- Candolin, U., 2003. The use of multiple cues in mate choice. *Biol. Rev.* 78, 575–595.
- Clotfelter, E.D., Bell, A.M., Levering, K.R., 2004. The role of animal behaviour in the study of endocrine-disrupting chemicals. *Anim. Behav.* 68, 665–676.
- Coe, T.S., Söfker, M.K., Filby, A.L., Hodgson, D., Tyler, C.R., 2010. Impact of early life exposure to estrogen on subsequent breeding behaviour and reproductive success in zebrafish. *Environ. Sci. Technol.* 44, 6481–6487.
- Colman, J.R., Baldwin, D., Johnson, L.L., Scholz, N.L., 2009. Effects of the synthetic estrogen 17 α -ethinylestradiol, on aggression and courtship behavior in male zebrafish (*Danio rerio*). *Aquat. Toxicol.* 91, 346–354.
- Corfield, J., Diggles, B., Jubb, C., McDowall, R.M., Moore, A., Richards, A., Rowe, D.K., 2008. Review of the Impacts of Introduced Ornamental Fish Species That Have Established Wild Populations in Australia. Prepared for the Australian Government Department of the Environment, Water, Heritage and the Arts, pp. 284–286.
- Crews, D., Gore, A.C., Hsu, T.S., Dangleben, N.L., Spinetta, M., Schallert, T., Anway, M.D., Skinner, M.K., 2007. Transgenerational epigenetic imprints on mate preference. *PNAS* 104, 5942–5946.
- Crow, R.T., Liley, N.R., 2011. A sexual pheromone in the guppy, *Poecilia reticulata* (Peters). *Can. J. Zool.* 57, 184–188.
- Darwin, C., 1859. In: Murray, J. (Ed.), *On the Origin of Species by Means of Natural Selection, or the Preservation of Favoured Races in the Struggle for Life*. London.
- Delpuech, J.M., Gareau, E., Terrier, O., Fouillet, P., 1998. Sublethal effects of the insecticide chlorpyrifos on the sex-pheromonal communication of *Trichogramma brassicae*. *Chemosphere* 36, 1775–1785.
- Delpuech, J.M., Legallet, B., Terrier, O., Fouillet, P., 1999. Modifications of the sex-pheromonal communication of *Trichogramma brassicae* by a sublethal dose of deltamethrin. *Chemosphere* 38, 729–739.
- Derouiche, L., Keller, M., Martini, M., Duittoz, A.H., Pillon, D., 2015. Developmental exposure to ethinylestradiol affects reproductive physiology, the GnRH neuroendocrine network and behaviors in female mouse. *Front. Neurosci.* 9, 463.
- Diamanti-Kandarakis, E., Bourguignon, J.P., Giudice, L.C., Hauser, R., Prins, G.S., Soto, A.M., Zoeller, R.T., Gore, A.C., 2009. Endocrine-disrupting chemicals: an endocrine society scientific statement. *Pediatr. Endocrinol. Rev.* 30, 293–342.
- Dosen, L.D., Montgomerie, R., 2004. Female size influences mate preferences of male guppies. *Ethology* 110, 245–255.
- Endler, J.A., 1980. Natural selection on color patterns in *Poecilia reticulata*. *Evolution* 76–91.
- Engqvist, L., 2005. The mistreatment of covariate interaction terms in linear model analyses of behavioural and evolutionary ecology studies. *Anim. Behav.* 70, 967–971.
- Fisher, H.S., Wong, B.B.M., Rosenthal, G.G., 2006. Alteration of the chemical environment disrupts communication in a freshwater fish. *Proc. R. Soc. B* 273, 1187–1193.
- Frankel, T.E., Meyer, M.T., Kolpin, D.W., Gillis, A.B., Alvarez, D.A., Orlando, E.F., 2016. Exposure to the contraceptive progestin, gestodene, alters reproductive behavior, arrests egg deposition, and masculinizes development in the fathead minnow (*Pimephales promelas*). *Environ. Sci. Technol.* 50, 5991–5999.
- Gasparini, C., Serena, G., Pilastro, A., 2013. Do unattractive friends make you look better? Context-dependent male mating preferences in the guppy. *Proc. R. Soc. B* 280, 20123072.
- Guevara-Fiore, P., Skinner, A., Watt, P.J., 2009. Do male guppies distinguish virgin females from recently mated ones? *Anim. Behav.* 77, 425–431.
- Hannah, R., D'Aco, V.J., Anderson, P.D., Buzby, M.E., Caldwell, D.J., Cunningham, V.L., Ericson, J.F., Johnson, A.C., Parke, N.J., Samuelian, J.H., Sumpter, J.P., 2009. Exposure assessment of 17 α -ethinylestradiol in surface waters of the United States and Europe. *Environ. Toxicol. Chem.* 28, 2725–2732.
- Henriksen, P.G., Beedholm, K., Baatrup, E., 2016. Differences in reproductive behavior between spawning and non-spawning zebrafish pairs and the effects of 17 α -ethinylestradiol (EE2). *Toxics* 4, 22.
- Herdman, E.J.E., Kelly, C.D., Godin, J.G.J., 2004. Male mate choice in the guppy (*Poecilia reticulata*): do males prefer larger females as mates? *Ethology* 110, 97–111.
- Heuschele, J., Candolin, U., 2007. An increase in pH boosts olfactory communication in sticklebacks. *Biol. Lett.* 3, 411–413.
- Hirschenhauser, K., Oliveira, R.F., 2006. Social modulation of androgens in male vertebrates: meta-analyses of the challenge hypothesis. *Anim. Behav.* 71, 265–277.
- Hoffmann, F., Kloas, W., 2012. The antiestrogens tamoxifen and fulvestrant abolish estrogenic impacts of 17 α -ethinylestradiol on male calling behavior of *Xenopus laevis*. *PLoS One* 7, e44715.
- Houde, A.E., 1997. *Sex, Color, and Mate Choice in Guppies*. Princeton University Press, Princeton, NJ.
- Jeswiet, S.B., Godin, J.G.J., 2011. Validation of a method for quantifying male mating preferences in the guppy (*Poecilia reticulata*). *Ethology* 117, 422–429.
- Kidd, K.A., Blanchfield, P.J., Mills, K.H., Palace, V.P., Evans, R.E., Lazorchak, J.M., Flick, R.W., 2007. Collapse of a fish population after exposure to a synthetic estrogen. *PNAS* 104, 8897–8901.
- King, O.C., van de Merwe, J.P., McDonald, J.A., Leusch, F.D.L., 2016. Concentrations of levonorgestrel and ethinylestradiol in wastewater effluent: is the progestin also cause for concern? *Env. Toxicol. Chem.* 35, 1378–1385.
- Knapp, R., Wingfield, J.C., Bass, A.H., 1999. Steroid hormones and paternal care in the plain n midshipman fish (*Porichthys notatus*). *Horm. Behav.* 35, 81–89.
- Larsen, M.G., Hansen, K.B., Henriksen, P.G., Baatrup, E., 2008. Male zebrafish (*Danio rerio*) courtship behaviour resists the feminizing effects of 17 α -ethinylestradiol—morphological sexual characteristics do not. *Aquat. Toxicol.* 87, 234–244.
- Lee, P.Y., Lin, C.Y., Chen, T.H., 2014. Environmentally relevant exposure of 17 α -ethinylestradiol impairs spawning and reproductive behavior in the brackish medaka *Oryzias latipes*. *Mar. Pollut. Bull.* 85, 338–343.
- Lehtonen, T.K., Kvarnemo, C., 2015. Odour cues from suitors' nests determine mating success in a fish. *Biol. Lett.* 11, 20150021.
- Lehtonen, T.K., Rintakoski, S., Lindström, K., 2007. Mate preference for multiple cues: interplay between male and nest size in the sand goby, *Pomatoschistus minutus*. *Behav. Ecol.* 18, 696–700.
- Lima, D.L.D., Silva, C.P., Otero, M., Esteves, V.I., 2013. Low cost methodology for estrogens monitoring in water samples using dispersive liquid-liquid microextraction and HPLC with fluorescence detection. *Talanta* 115, 980–985.
- Lurling, M., Scheffer, M., 2007. Info-disruption: pollution and the transfer of chemical information between organisms. *Trends Ecol. Evol. (Amst.)* 22, 374–379.
- Luyten, P.H., Liley, N.R., 1991. Sexual selection and competitive mating success of males guppies (*Poecilia reticulata*) from four Trinidad populations. *Behav. Ecol. Sociobiol.* 28, 329–336.
- Magee, S.E., Neff, B.D., Knapp, R., 2006. Plasma levels of androgens and cortisol in relation to breeding behavior in parental male bluegill sunfish, *Lepomis macrochirus*. *Horm. Behav.* 49, 598–609.
- Magurran, A.E., Seghers, B.H., 1994. A cost of sexual harassment in the guppy, *Poecilia reticulata*. *Proc. R. Soc. B* 258, 89–92.
- Majewski, A.R., Blanchfield, P.J., Palace, V.P., Wautier, K., 2002. Waterborne 17 α -ethinylestradiol affects aggressive behaviour of male fathead minnows (*Pimephales promelas*) under artificial spawning conditions. *Water Qual. Res. J. Can.* 37, 697–710.
- Martin, J.M., Saaristo, M., Bertram, M.G., Lewis, P.J., Coggan, T.L., Clarke, B.O., Wong, B.B.M., 2017. The psychoactive pollutant fluoxetine compromises antipredator behaviour in fish. *Environ. Pollut.* 222, 592–599.
- Melvin, S.D., Wilson, S.P., 2013. The utility of behavioral studies for aquatic toxicology testing: a meta-analysis. *Chemosphere* 93, 2217–2223.
- Moore, A., Waring, C.P., 1996. Sublethal effects of the pesticide diazinon on olfactory function in mature male Atlantic salmon parr. *J. Fish Biol.* 48, 758–775.
- Moore, A., Waring, C.P., 1998. Mechanistic effects of a triazine pesticide on reproductive endocrine function in mature male Atlantic salmon (*Salmo salar* L.). parr. *Pest. Biochem. Physiol.* 62, 41–50.
- Moore, A., Waring, C.P., 2001. The effects of a synthetic pyrethroid pesticide on some aspects of reproduction in Atlantic salmon (*Salmo salar* L.). *Aquat. Toxicol.* 52, 1–12.
- Oliveira, R.F., Hirschenhauser, K., Carneiro, Luis A., Canario, A.V., 2002. Social modulation of androgen levels in male teleost fish. *Comp. Biochem. Physiol., B* 132, 203–215.
- Pandey, S.P., Tsutsui, K., Mohanty, B., 2017. Endocrine disrupting pesticides impair the neuroendocrine regulation of reproductive behaviors and secondary sexual characters of red munia (*Amandava amandava*). *Physiol. Behav.* 173, 15–22.
- Pankhurst, N.W., Hilder, P.I., Pankhurst, P.M., 1999. Reproductive condition on and behavior in relation to plasma levels of gonadal steroids in the spiny damselfish *Acanthochromis polyacanthus*. *Gen. Comp. Endocr.* 115, 53–69.
- Park, D., Propper, C.R., 2002. Endosulfan affects pheromonal detection and glands in the male red-spotted newt, *Notophthalmus viridescens*. *Bull. Environ. Contam. Toxicol.* 69, 609–616.
- Park, D., Hempleman, S.C., Propper, C.R., 2001. Endosulfan exposure disrupts pheromonal systems in the red-spotted newt: a mechanism for subtle effects of environmental chemicals. *Environ. Health Perspect.* 109, 669–703.
- Quinn, G.P., Keough, M.J., 2002. *Experimental Design and Data Analysis for Biologists*. Cambridge University Press, New York.
- Rodgers, E.W., Earley, R.L., Grober, M.S., 2006. Elevated 11-ketotestosterone during paternal behavior in the Bluebanded goby (*Lythrypnus dalli*). *Horm. Behav.* 49, 610–614.
- Ros, A.F.H., Bruinijes, R., Santos, R.S., Canario, A.V.M., Oliveira, R.F., 2004. The role of androgens in the trade-off between territorial and parental behavior in the Azorean rock-pool blenny, *Parablennius parvicornis*. *Horm. Behav.* 46 (491–), 497.
- Saaristo, M., Craft, J.A., Lehtonen, K.K., Björk, H., Lindström, K., 2009a. Disruption of sexual selection in sand gobies (*Pomatoschistus minutus*) by 17 α -ethinyl estradiol, an endocrine disruptor. *Horm. Behav.* 55, 530–537.
- Saaristo, M., Craft, J.A., Lehtonen, K.K., Lindström, K., 2009b. Sand goby (*Pomatoschistus minutus*) males exposed to an endocrine disrupting chemical fail in nest and mate competition. *Horm. Behav.* 56, 315–321.
- Saaristo, M., Craft, J.A., Lehtonen, K.K., Lindström, K., 2010a. Exposure to 17 α -ethinyl estradiol impairs courtship and aggressive behaviour of male sand goby (*Pomatoschistus minutus*). *Chemosphere* 79, 541–546.
- Saaristo, M., Craft, J.A., Lehtonen, K.K., Lindström, K., 2010b. An endocrine disrupting chemical changes courtship and parental care in the sand goby. *Aquat. Toxicol.* 97, 285–292.
- Saaristo, M., McLennan, A., Johnstone, C.P., Clarke, B., Wong, B.B.M., 2017. Impacts of the antidepressant fluoxetine on the anti-predator behaviour of wild guppies (*Poecilia reticulata*). *Aquat. Toxicol.* 183 (38–), 45.
- Saaristo, M., Brodin, T., Balshine, S., Bertram, M.G., Brooks, B.W., Ehlman, S.M., McCallum, E.S., Sih, A., Sundin, J., Wong, B.B.M., Arnold, K.E., 2018. Direct and indirect effects of chemical contaminants on the behaviour, ecology and evolution of wildlife. *Proc. R. Soc. B* 285 20181297.
- Salierno, J.D., Kane, A.S., 2009. 17 α -ethinylestradiol alters reproductive behaviors, circulating hormones, and sexual morphology in male fathead minnows (*Pimephales promelas*). *Environ. Toxicol. Chem.* 28, 953–961.
- Santos, D., Matos, M., Coimbra, A.M., 2014. Developmental toxicity of endocrine disruptors in early life stages of zebrafish, a genetic and embryogenesis study. *Neurotoxicol. Teratol.* 46, 18–25.
- Tiedeken, E.J., Tahar, A., McHugh, B., Rowan, N.J., 2017. Monitoring, sources, receptors, and control measures for three European Union watch list substances of emerging concern in receiving waters - A 20 year systematic review. *Sci Total Env.* 574, 1140–1163.

- Tierney, K.B., Baldwin, D.H., Hara, T.J., Ross, P.S., Scholz, N.L., Kennedy, C.J., 2010. Olfactory toxicity in fishes. *Aquat. Toxicol.* 96, 2–26.
- Tomkins, P., Saaristo, M., Allinson, M., Wong, B.B.M., 2016. Exposure to an agricultural contaminant, 17 β -trenbolone, impairs female mate choice in a freshwater fish. *Aquat. Toxicol.* 170, 365–370.
- Tomkins, P., Saaristo, M., Bertram, M.G., Tomkins, R.B., Allinson, M., Wong, B.B.M., 2017. The agricultural contaminant 17 β -trenbolone disrupts male-male competition in the guppy (*Poecilia reticulata*). *Chemosphere* 187, 286–293.
- Tomkins, P., Saaristo, M., Bertram, M.G., Michelangeli, M., Tomkins, R.B., Wong, B.B.M., 2018. An endocrine-disrupting agricultural contaminant impacts sequential female mate choice in fish. *Environ. Pollut.* 237, 103–110.
- United Nations, 2015. Department of Economic and Social Affairs, Population Division. Trends in Contraceptive Use Worldwide 2015 (ST/ESA/SER.A/349).
- Vu, M., Navarro-Martín, L., Gutierrez-Villagomez, J.M., Trudeau, V.L., 2015. Development of an in vitro ovary culture system to evaluate endocrine disruption in wood frog tadpoles. *J. Toxicol. Environ. Health A* 78, 1137–1141.
- Walling, C.A., Royle, N.J., Lindström, J., Metcalfe, N.B., 2010. Do female association preferences predict the likelihood of reproduction? *Behav. Ecol. Sociobiol.* 64, 541–548.
- Wingfield, J.C., Hegner, R.E., Dufty Jr., A.M., Ball, G.F., 1990. The ‘challenge hypothesis’: theoretical implications for patterns of testosterone secretion, mating systems, and breeding strategies. *Am. Nat.* 136, 829–846.
- Wong, B.B.M., Candolin, U., 2005. How is female mate choice affected by male competition? *Biol. Rev.* 80, 559–571.
- Wong, B.B.M., Candolin, U., 2015. Behavioral responses to changing environments. *Behav. Ecol.* 26, 665–673.
- Wong, B.B.M., Fisher, H.S., Rosenthal, G.G., 2005. Species recognition by male swordtails via chemical cues. *Behav. Ecol.* 16, 818–822.
- Wong, B.B.M., Candolin, U., Lindström, K., 2007. Environmental deterioration compromises socially enforced signals of male quality in three-spined sticklebacks. *Am. Nat.* 184–189.
- Zala, S.M., Penn, D.J., 2004. Abnormal behaviours induced by chemical pollution: a review of the evidence and new challenges. *Anim. Behav.* 68, 649–664.